

ADONIS-C1 PRINTER CONTROLLER

(Code: B358)

The B358 printer controller option is based on the A850, which is the printer controller option for the NAD30/40.

The differences from the A850 are written in *Italics* in this manual.

TABLE OF CONTENTS

1. OVERALL MACHINE INFORMATION	1-1
1.1 INTRODUCTION	1-1
1.2 SPECIFICATIONS	1-2
1.3 SOFTWARE	1-2
1.3.1 PRINTER DRIVERS	1-2
1.3.2 NETWORK UTILITIES	1-2
1.4 MACHINE CONFIGURATION	1-3
1.5 STRUCTURE	1-4
1.5.1 BLOCK DIAGRAM	1-4
1.5.2 DESCRIPTIONS	1-5
2. DETAILED SECTION DESCRIPTIONS.....	2-1
2.1 HARDWARE OVERVIEW	2-1
2.2 IMAGE PRINTING	2-3
2.3 IMAGE DATA PROCESSING	2-4
2.3.1 EDGE SMOOTHING	2-4
2.3.2 TONER SAVING MODE	2-4
2.4 FEATURES	2-5
2.4.1 SORTING	2-5
2.4.2 DUPLEX PRINTING	2-5
2.4.3 STAPLING	2-6
2.4.4 PUNCHING	2-6
2.4.5 JAM RECOVERY	2-7
2.4.6 AUTO TRAY SELECT	2-7
2.4.7 POWER ON SELF DIAGNOSTICS	2-7
2.5 HARD DISK	2-8
2.5.1 PRINTER HDD	2-8
2.5.2 ENGINE HDD	2-8
2.6 PAPER HEIGHT DETECTION	2-9
2.7 PAPER OVERFLOW DETECTION	2-10
2.7.1 STANDARD OUTPUT TRAY	2-10
2.7.2 BRIDGE UNIT	2-10
3. INSTALLATION PROCEDURE	3-1
3.1 PRINTER CONTROLLER.....	3-1
3.1.1 ACCESSORY CHECK.....	3-1
3.1.2 REQUIRED MAIN MACHINE OPTIONS	3-1
3.1.3 INSTALLATION PROCEDURE.....	3-2
3.2 HARD DISK	3-8
3.2.1 INSTALLATION PROCEDURE.....	3-8
3.3 POSTSCRIPT KIT	3-9
3.3.1 INSTALLATION PROCEDURE.....	3-9
3.4 NETWORK INTERFACE BOARD	3-10
3.4.1 INSTALLATION PROCEDURE.....	3-10

3.5	DRAM SIMM.....	3-11
3.5.1	REQUIRED SPECIFICATION CHECK.....	3-11
3.5.2	INSTALLATION PROCEDURE.....	3-11
3.6	CONNECTING THE INTERFACE CABLES.....	3-12
3.6.1	PARALLEL INTERFACE.....	3-12
3.6.2	NETWORK INTERFACE.....	3-12
3.7	CHECKING THE CONNECTIONS.....	3-12
3.7.1	CONNECTION BETWEEN PRINTER CONTROLLER (AND RELATED OPTIONS; POSTSCRIPT ROM, DRAM SIMM, HARD DISK DRIVE, NIB) AND ENGINE.....	3-12
3.7.2	CONNECTION BETWEEN MAIN CONTROLLER BOARD AND THE NETWORK INTERFACE BOARD.....	3-14
4.	SERVICE TABLE.....	4-1
4.1	GENERAL CAUTION.....	4-1
4.2	SERVICE PROGRAM MODE.....	4-1
4.2.1	SERVICE PROGRAM ACCESS PROCEDURE.....	4-1
4.2.2	SERVICE PROGRAM MODE TABLES.....	4-1
4.3	DOWNLOADING NEW FIRMWARE.....	4-2
4.3.1	FIRMWARE UPDATE USING A FLASH MEMORY CARD (SP02 AND 04).....	4-2
4.3.2	FIRMWARE UPDATE FROM PARALLEL PORT (SP01 AND 03).....	4-3
4.3.3	FORMATTING THE HARD DISK (SP06).....	4-3
4.3.4	COPY FLASH ROM (SP05).....	4-4
4.3.5	PARALLEL LOOP BACK TEST (SP11).....	4-5
4.4	USER PROGRAM MODE.....	4-6
4.4.1	UP MODE TABLE.....	4-6
4.5	DIP SWITCHES/JUMPER PINS/LEDS.....	4-7
4.5.1	DIP SWITCHES.....	4-7
4.5.2	JUMPER PINS.....	4-7
4.5.3	LEDS.....	4-7
4.6	SPECIAL TOOLS.....	4-7
5.	REPLACEMENT AND ADJUSTMENT.....	5-1
5.1	PRINTER CONTROLLER BOARD.....	5-1
5.2	HARD DISK.....	5-2
5.3	NETWORK INTERFACE BOARD.....	5-2
5.3.1	POSTSCRIPT ROM BOARD AND DRAM SIMM.....	5-3
6.	TROUBLESHOOTING.....	6-1
6.1	ERROR MESSAGES.....	6-1
6.2	LEDS.....	6-3
6.2.1	LOCATION.....	6-3
6.2.2	LED CODE TABLE.....	6-3

1. OVERALL MACHINE INFORMATION

1.1 INTRODUCTION

The *Adonis-C1* base engine contains an interface for the *Adonis-C1* multi-function controller. The *Adonis-C1* multi-function controller adds fax and/or printer functions. Printer and fax functions can operate independently and simultaneously with other functions in the background, and their output will be interleaved with the copy mode output.

The printer supports the PCL6, and PostScript level 3. PostScript language support is an optional function.

Host printer data can be received via the standard parallel port or the optional Network Interface Board (NIB). The parallel port supports bi-directional Command and Status feed back communication with the host machines.

An optional IDE hard disk drive provides font download and other functions.

Additional DRAM SIMMs can be installed to boost the printer performance.

Images can be rasterized at 300, 400, or 600 dpi in the controller but printed at 400 or 600 dpi. For 300 dpi printing, the 300 dpi data from the controller is simulated in the base engine by printing the same pixel twice and the same line twice at 600 dpi.

The *Adonis-C1b* engine can print 35 pages per minute at both 400 and 600 dpi. On the other hand, the *Adonis-C1c* engine can print 45 pages per minute at both 400 and 600 dpi.

1.2 SPECIFICATIONS

Resolution:	600 x 600 dpi 400 x 400 dpi (available when the PostScript option is installed) 300 x 300 dpi (simulated by doubling pixel width and height at 600 dpi resolution)
Printing Speed:	35 ppm (<i>Adonis-C1b</i>) 45 ppm (<i>Adonis-C1c</i>)
Printing Emulation:	Main Controller Board: PCL5e and PCL6 Optional PS Board: PostScript Level 3
Printer Font:	45 scaleable typefaces in 14 typeface families (35 Intellifont and 10 TrueType format fonts) 1 bitmapped typeface in the Line Printer typeface family
Printer Interface:	Bi-directional Parallel x 1 (Standard) Network Interface x 1 (Option) Ethernet (100 base-TX/10 base-T for TCP/IP, IPX/SPX, EtherTalk)
DRAM Capacity:	8 MB (Standard) 2 DRAM SIMM slots (up to 64 MB) Maximum Total: Up to 72 MB

1.3 SOFTWARE

1.3.1 PRINTER DRIVERS

The following printer drivers are enclosed in the drivers and utilities CD-ROM.

- PCL5e Printer Driver for Windows 95/98/2000/NT4.0
- PCL6 Printer Driver for Windows 95/98/2000/NT4.0
- PS3 Printer Driver for Windows 95/98/2000/NT4.0 and Macintosh

1.3.2 NETWORK UTILITIES

The network utilities are enclosed in the Network Interface Board option. Refer to the NIB manual for details.

1.4 MACHINE CONFIGURATION

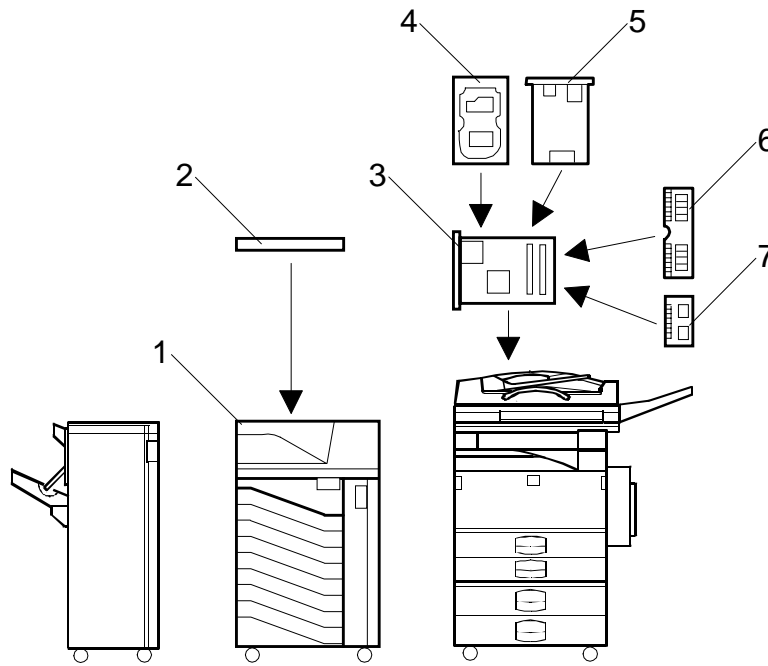

B358V500.WMF

Item	Machine Code	No.
Printer Controller	B358	3
PostScript Kit	A854	7
Hard Disk	A853	4
Network Interface Board	A855	5
Mailbox	G909	1
Mailbox Bridge Unit	G912	2
RAM SIMM	---	6

Relationship between Main Machine, Mailbox, and Finisher

O: Available X: Not available

Model	Mailbox	1,000 sheet Finisher	3,000 sheet Finisher
Adonis-C1b	Installed	X	X
	Not installed	O	X
Adonis-C1c	Installed	X	O
	Not installed	O	O

1.5 STRUCTURE

1.5.1 BLOCK DIAGRAM

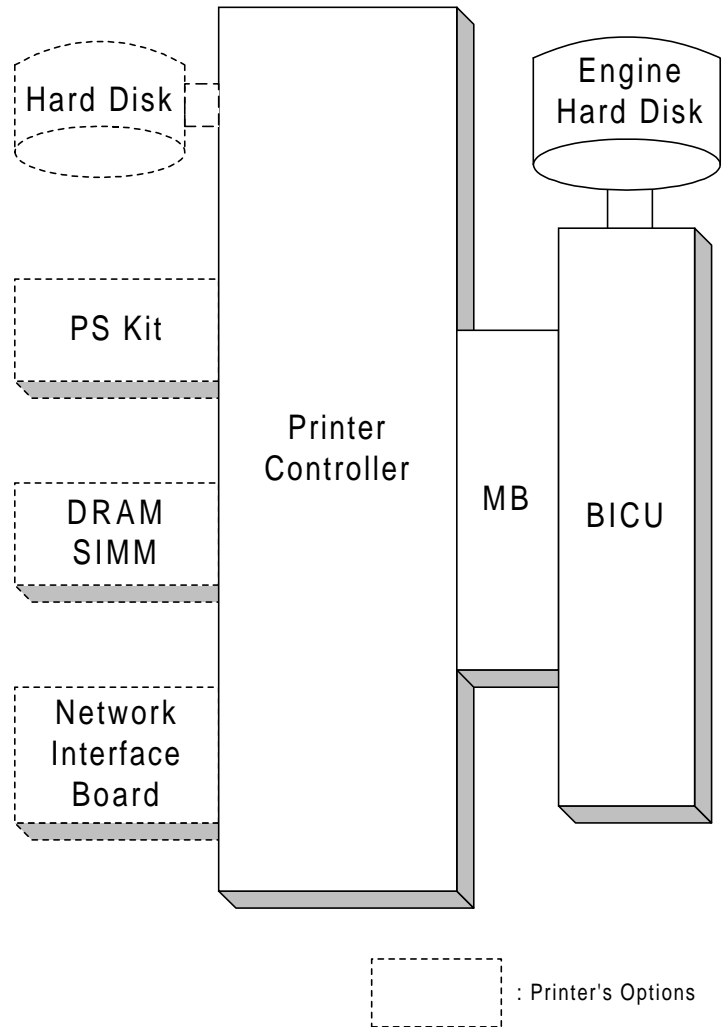

B358V501.WMF

1.5.2 DESCRIPTIONS

1. Printer Controller

The printer controller handles the following functions:

- Printer host interface
- Printing functions
- Interface and control of additional controller options (HDD, PS kit, DRAM SIMM, and network interface board)

2. Hard Disk (option)

This HDD stores the additional soft fonts (both PCL and PS fonts).

3. PS Kit (option)

This is to add the PostScript level 3 feature.

4. Network Interface Board (option)

The network interface board is an additional printer interface to allow the printer to be used on a network.

5. DRAM SIMM (option)

There are two DRAM SIMM slots. This is used for an additional printer processing memory area. 8, 16, or 32 Mbyte standard SIMM modules can be installed. As a result, up to 72 Mbytes of RAM are installable (8 Mbytes on board plus 64 Mbytes of optional SIMM).

6. MB (Mother Board)

This connects the controller to the BICU board in the base machine.

2. DETAILED SECTION DESCRIPTIONS

2.1 HARDWARE OVERVIEW

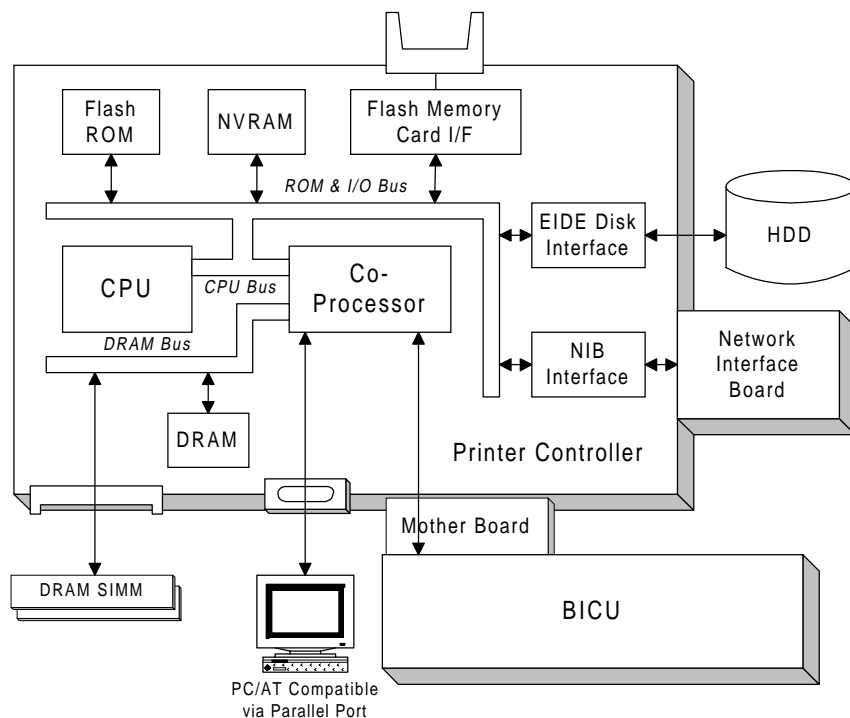

B358D500.WMF

The above block diagram shows the major components of the printer controller. The main features of the controller are as follows.

1. CPU

An IBM PPC603 (100 MHz) processor is used. A 33 MHz oscillator is used as the base clock for both this CPU and the coprocessor.

2. Co-processor

This performs the following functions.

- ROM control
- I/O control
- DRAM control
- Printer video interface
- Printer communication interface
- IEEE 1284 compliant bi-directional parallel port interface
- Interrupt control

Detailed Descriptions

3. ROM memory**1) Flash ROM (4 Mbytes)**

This flash ROM includes boot code, operation system code, PCL5e codes, PCL6 code, and font data for both PCL languages (resident fonts).

2) ROM SIMM (4 Mbytes for the PostScript option)

This ROM SIMM includes the PostScript code and PostScript font data.

4. NVRAM (8 Kbytes)

This NVRAM contains the printer settings, job record data, and error record data.

5. Network Interface Board Interface

This controls the optional network interface board, and printer MIB is provided to support the network operations.

6. Hard Disk Drive Interface (Enhanced IDE)

This HDD interface is provided to support storage of fonts downloaded from a PC.

7. Flash Memory Card Interface

The flash memory card for updating the controller and PostScript firmware is connected to this flash memory card slot.

8. Power-on Self Diagnostic

When the controller is turned on, the controller performs a self diagnostic test.

2.2 IMAGE PRINTING

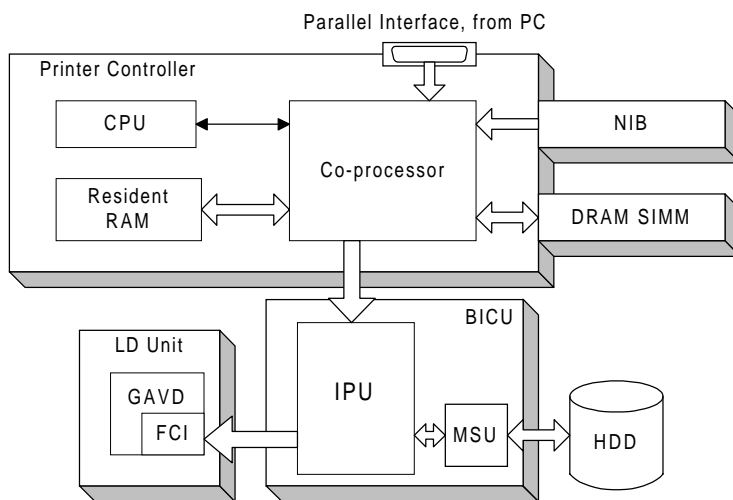

B358D502.WMF

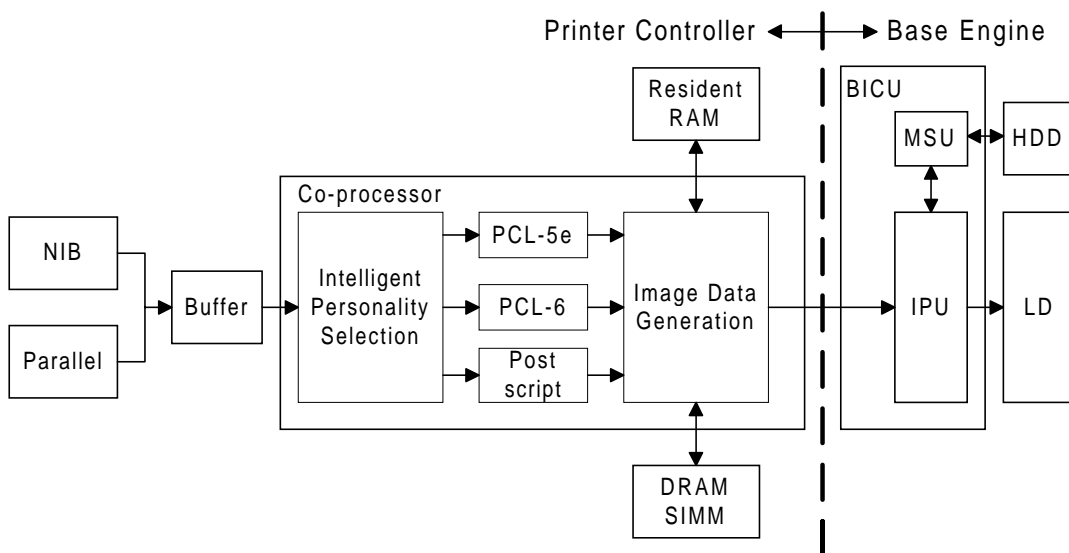

B358D503.WMF

The printer controller receives the print data from the computer through the parallel or network interface port. The co-processor handles the image data but it only makes a raster image. All image processing, such as edge smoothing and toner saving, are done in the base engine.

The image data from a PC goes to the buffer in the resident RAM. Then, it goes to the co-processor. The co-processor selects the printer language automatically, then the co-processor generates the print data to match the selected printer language. After generating the print data, the co-processor sends it to the LD unit through the IPU on the BICU board. At that time, the data is also sent to the hard disk for multiple printing and sorting, as well as backup in case of paper jams.

Detailed Descriptions

2.3 IMAGE DATA PROCESSING

The FCI in the LD unit is responsible for edge smoothing and toner saving functions.

The edge smoothing and toner saving modes can be switched on or off using the printer user tool or the printer driver.

2.3.1 EDGE SMOOTHING

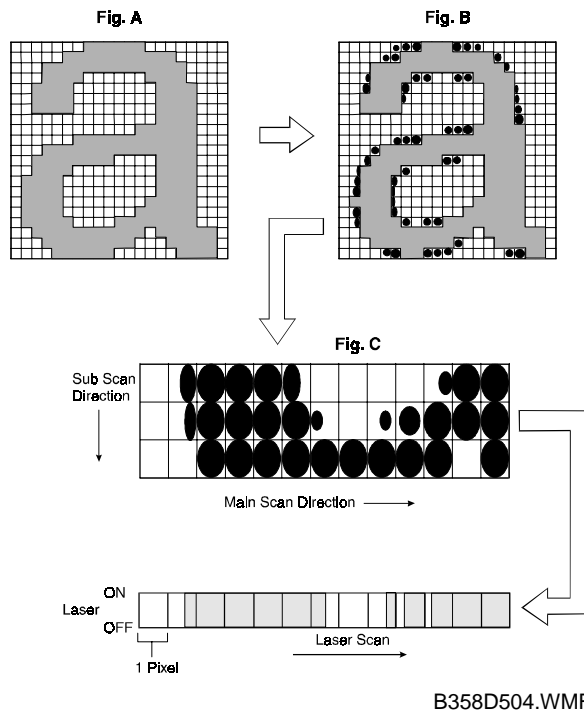

Usually, binary picture processing generates jagged edge on characters as shown in the above left illustration. The FCI reduces the edges of characters using edge smoothing.

Whether or not the object pixel undergoes smoothing depends on the surrounding image data. Smoothing for the object pixel is done by changing the laser pulse position.

2.3.2 TONER SAVING MODE

Toner saving is done by reducing the number of black dots printed, not by varying the development bias. In toner saving mode, the image data is filtered through a matrix.

As a result of passing through the filter, less toner is used to create the latent image on the drum, and black areas print as gray.

2.4 FEATURES

2.4.1 SORTING

If “Collate” is turned on and a multicopy job is printed, the first copy of the job will be printed directly. At the same time, the image data for the copy job is stored in the hard disk of the main machine. When the main machine prints the next copy, the next copy will be printed from the hard disk.

If the finisher is not installed, the rotate sort feature can be used. The MSU block in the BICU board rotates the image, in the same way as image rotation for the copier.

2.4.2 DUPLEX PRINTING

Duplex printing is available with all output bin options but not all paper sizes (refer to the specifications section of the copier manual). If a job specifies duplex but the paper size to be used is not usable in the duplex unit, the job will be printed simplex.

Duplex printing is available in two binding methods: Short-edge binding and Long-edge binding.

In short-edge binding, when printing the second side of a page, the image may require rotation. The image is rotated by the co-processor in the printer controller.

The co-processor corrects the image printing order for duplexing as follows.

- Larger than A4 lengthwise/LT lengthwise (example 8 pages)
2nd page – 1st page – 4th page – 3rd page – 6th page – 5th page – 8th page – 7th page
- Up to A4 lengthwise/LT lengthwise (example 8 pages)
2nd page – 4th page – 1st page – 6th page – 3rd page – 8th page – 5th page – 7th page

2.4.3 STAPLING

Stapling is only available when the 3,000-sheet finisher or 1,000-sheet finisher is installed.

The finishers have the following stapling positions.

- 1) Upper left, diagonal
- 2) Upper right, diagonal
- 3) Left, two staples
- 4) Top, two staples
- 5) Right, two staples
- 6) Upper left, horizontal
- 7) Upper right, horizontal
- 8) Upper left, vertical
- 9) Upper right, vertical

NOTE: With the 1,000-sheet finisher, only stapling positions 1) and 2) are available.

Depending on the paper orientation, the image may have to be rotated. This image rotation is done by the co-processor in the printer controller.

There is a limit for the number of sheets which can be stapled by each finisher. If a job that specifies stapling has more than this number of sheets, it will not be stapled.

2.4.4 PUNCHING

Punching is only available when the punch unit is installed with the 3,000-sheet finisher. The number of holes depends on the type of punching unit. The punching unit has only one available position, so the relationship between the punching position and the printed image depends on the paper feeding orientation and imaging. The punching positions are defined as follows.

- 1) Left
- 2) Top
- 3) Right

2.4.5 JAM RECOVERY

If the jam recovery feature is on and a paper jam occurs, the controller will reprint all pages for which a feed-out indication has not been received from the main machine. In usual cases, all image data from the controller will be sent to the hard disk on the main machine, When a jam occurs, the recovery data will be sent from the hard disk on the main machine.

2.4.6 AUTO TRAY SELECT

When "Auto Select" is selected with the printer driver, the printer searches for a tray that contains the specified size of normal plain paper. The search starts from the LCT, and when a tray that contains the specified size of paper is found, the printer starts printing and feeds paper from that tray. The search sequence is as follows.

LCT – 1st tray – 2nd tray – 3rd tray – 4th tray – LCT

The default setting for the current tray is LCT. If the LCT is not installed, the default is the 1st tray.

2.4.7 POWER ON SELF DIAGNOSTICS

When the controller is turned on, it performs a self diagnostic sequence of tests automatically. If any errors were detected, an error message will be displayed on the operation panel.

Test Items

Devices always tested

- Co-processor
- Flash ROM
- Resident RAM
- NVRAM
- Engine I/F

Devices tested when they are installed

- DRAM SIMM
- PS DIMM I/F
- HDD I/F
- Network interface board I/F

2.5 HARD DISK

Two hard disks are used for the printer functions. One is connected to the printer controller (Printer HDD). The other is in the main machine (Engine HDD).

2.5.1 PRINTER HDD

When the main power switch is turned on after the printer HDD is installed, the machine asks you to format the hard disk.

If you press the “Yes” button, the machine formats the hard disk. At this time, two partitions will be made on the hard disk. One is for PCL and the other is for PostScript (fonts and macros only).

If you press the “Ignore” button, the machine determines that there is no optional printer hard disk.

2.5.2 ENGINE HDD

The hard disk in the main machine is used for both copy and printer functions. Therefore, the hard disk has three partitions: for copier, printer, and archive files (one of the copier features). *The sizes of the partitions depend on the setting of “User Tools – 1. System – No.23, Memory Priority”, as shown below.*

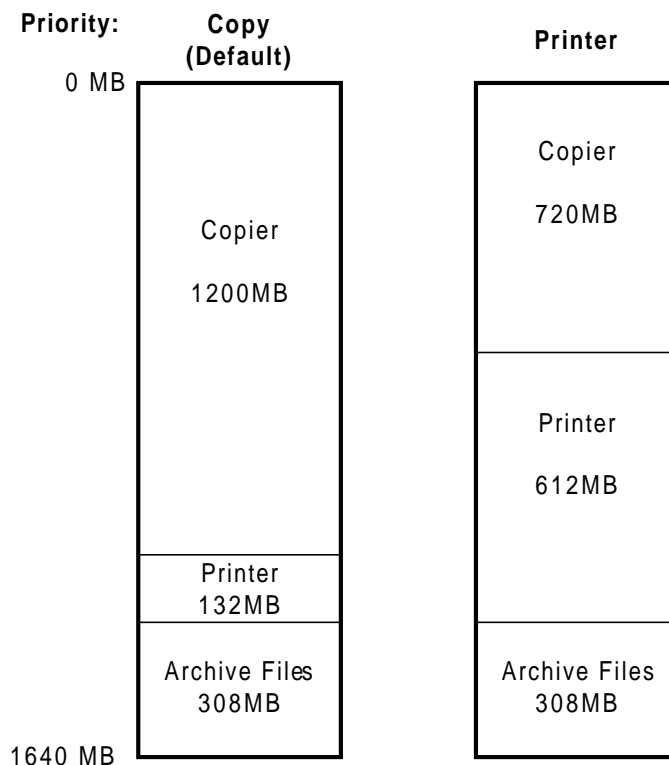

B358D505.WMF

2.6 PAPER HEIGHT DETECTION

The amount of paper in the tray is detected by the combination of two paper height sensors [A] and [B].

When the amount of paper decreases, the bottom plate pressure lever [C] moves up and the actuator [D] which is mounted on the same drive shaft as the pressure lever rotates.

The following combination of sensor signals is sent to the printer controller.

Amount of Paper	Paper Height Sensor [A]	Paper Height Sensor [B]
Full	OFF	ON
Near Full	ON	ON
Near End 1	ON	OFF
Near End 2	OFF	OFF

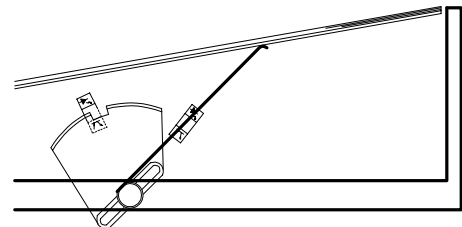
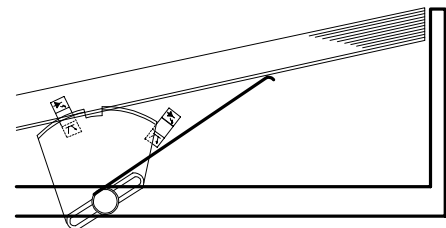
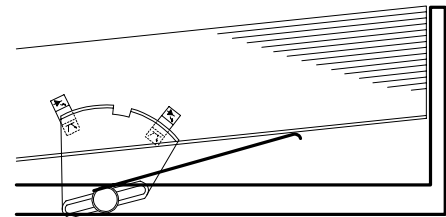
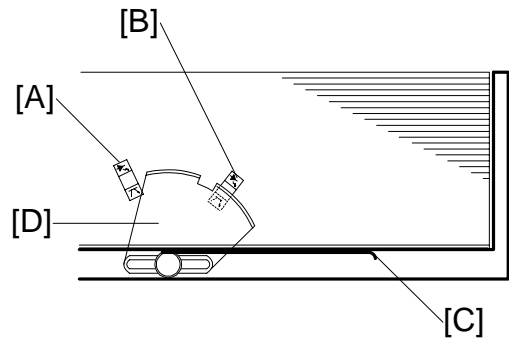

Detailed Descriptions

B358D506.WMF

2.7 PAPER OVERFLOW DETECTION

2.7.1 STANDARD OUTPUT TRAY

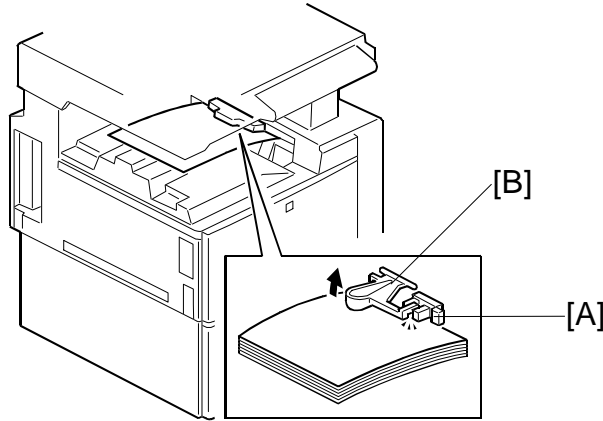

B358D507.WMF

The standard output tray can stack about 500-sheets. There is a paper limit sensor [A] to prevent paper overflow.

When the tray is full, the paper stack pushes up the feeler [B] then the paper limit sensor is activated. When the sensor stays activated for a certain time, the machine determines that the standard tray is full. The machine stops the print job until the paper limit sensor is deactivated.

2.7.2 BRIDGE UNIT

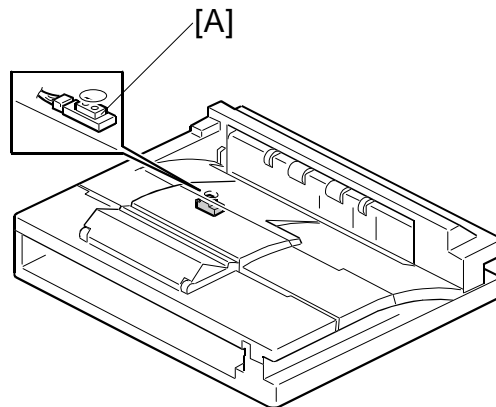

B358D508.WMF

The bridge unit has a paper sensor [A] to detect paper on the bridge unit. This is monitored to ensure that the bridge unit does not contain more than 250-sheets. If a print job of more than 250-sheets is executed, the machine will print up to 250 pages, then the print job is stopped. Once the output stack is removed, the printing job automatically continues.

3. INSTALLATION PROCEDURE

3.1 PRINTER CONTROLLER

3.1.1 ACCESSORY CHECK

Check the accessories in the box against the following list.

No.	Description	Q'ty
1	Cable	1
2	Paper Height Sensor	4
3	Edge Clamp	2
4	Cable Clamp	4
5	Paper Height Sensor Feeler	2
6	Paper Sensor	1
7	Key Top - Copy/Printer	1
8	Paper Limit Sensor Unit	1
9	Tapping Screw - M3 x 8	2
10	Pan Head Screw – M3 x 8	1
11	Tapping Screw - M3 x 6	2
12	Installation Procedure	1

3.1.2 REQUIRED MAIN MACHINE OPTIONS

Please note that it is necessary to first install the Expansion Box Type 450e (A872).

3.1.3 INSTALLATION PROCEDURE

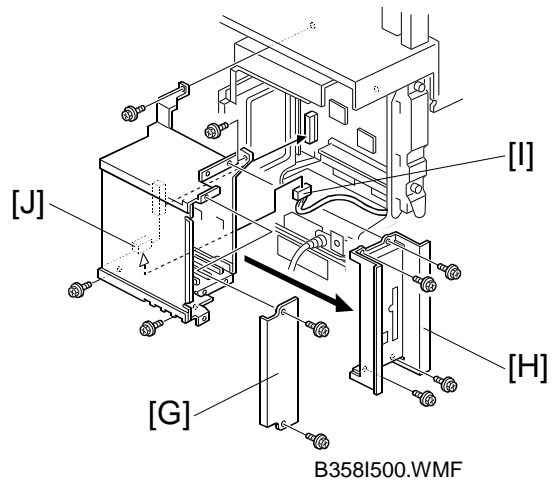
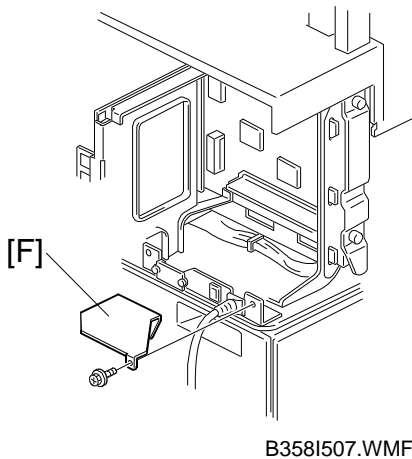
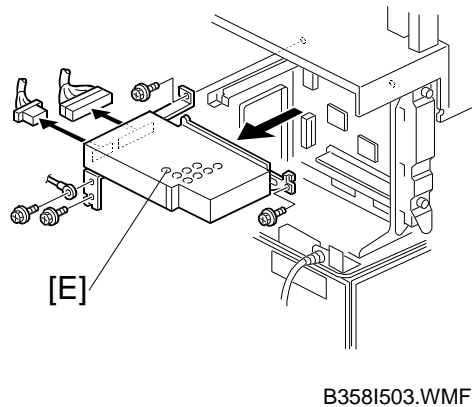
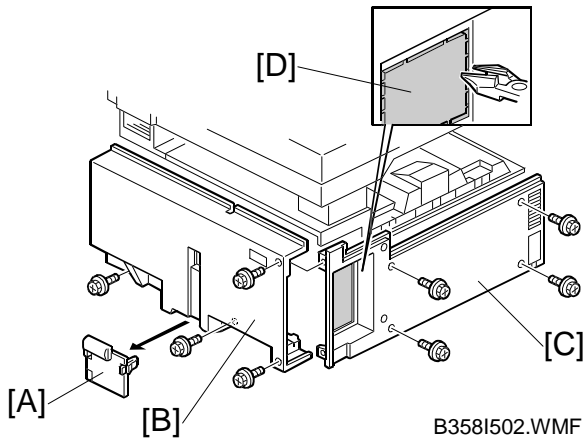

⚠ CAUTION
Unplug the main machine power cord before starting the following procedure.

Expansion Box Installation

NOTE: If either the Scanner Option Type 450e or Fax Option Type 450e has been installed, skip steps 1 through 8.

1. Remove the connector cover [A], rear cover [B] (4 screws), and left cover [C] (4 screws).
2. Remove the cutout [D] in the left cover.
3. Remove the HDD [E] (4 screws, 2 connectors).
4. Remove the bracket [F] (1 screw).
5. Remove the two plates [G] (2 screws) and [H] (4 screws).
6. Connect the cable [I] to the expansion box [J] and install the expansion box (4 screws).
7. Reinstall the HDD.
8. Reinstall the left, rear, and connector covers.

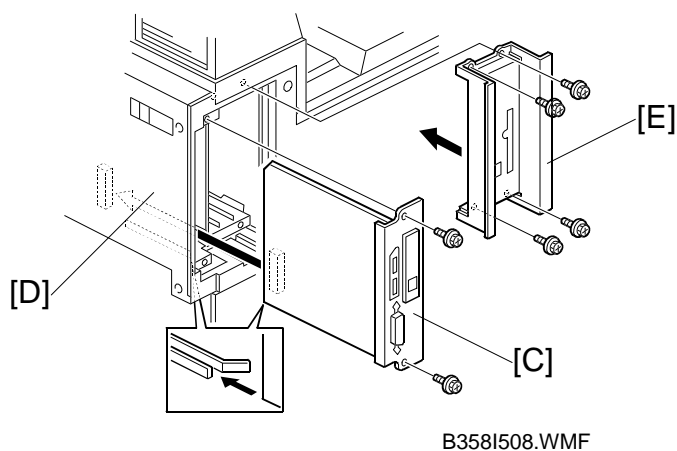
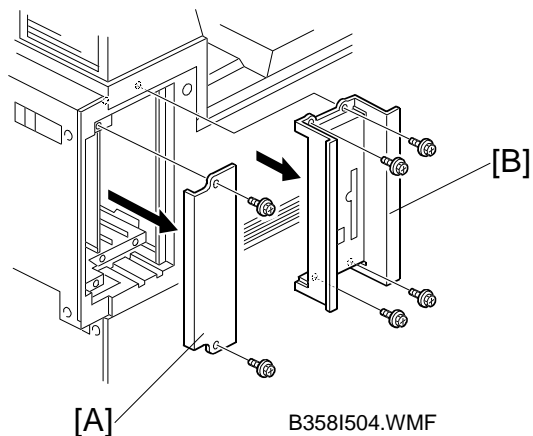

Installation

Printer Controller Installation

- NOTE:** 1) The optional HDD (A853), PS Kit (A854) or Network Interface Board (A855) must be installed before installing the printer controller in the machine. Refer to each installation manual for more detail.
- 2) If either the Scanner Option Type 450e or Fax Option Type 450e has been installed, perform step 9. If neither have been installed, skip step 9.
9. Remove the two plates [A] (2 screws) and [B] (4 screws).
 10. After installing the additional options on the printer controller, install the controller [C] in the left-most slot of the expansion box [D] (2 screws).
 11. Reattach plate [E].

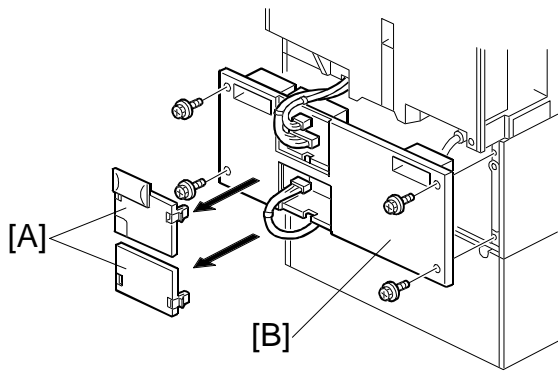

B358I510.WMF

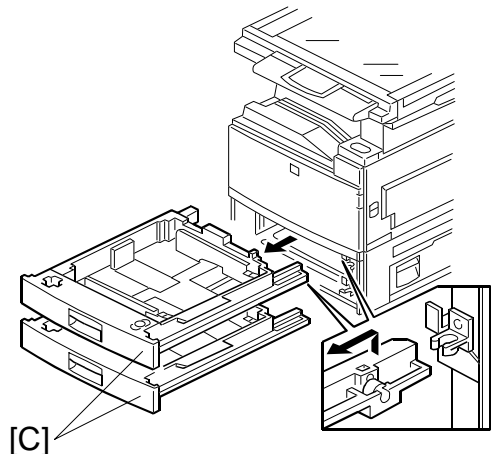

B358I511.WMF

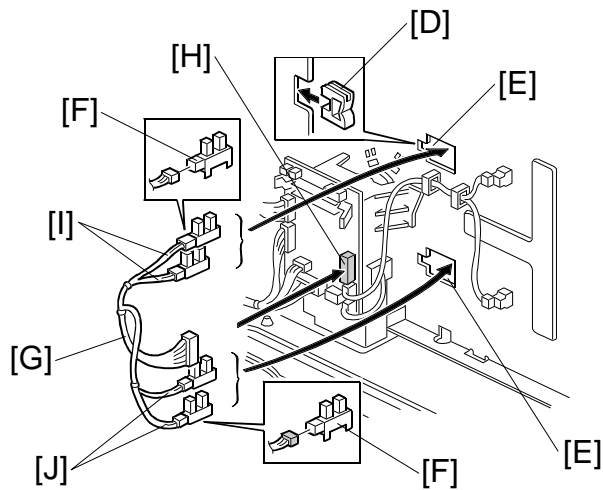

B358I512.WMF

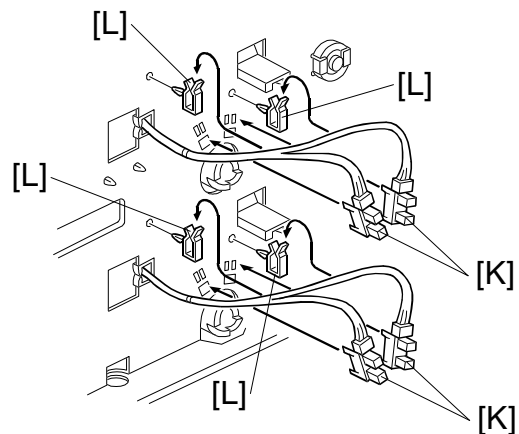

B358I513.WMF

Paper Height Sensor Installation

12. Remove the connector covers [A] and lower rear cover [B] (4 screws, 3 connectors).
13. Pull out the two paper trays [C].
14. Install edge clamps [D] in both openings [E].
15. Connect the four paper height sensors [F] to the cable [G].
16. Connect the cable to CN234 of the PCB [H].
17. Pass the two sensors attached to the white connector [I] through the upper opening. Pass the other two sensors attached to the red connector [J] through the lower opening. Secure the cables in place with the edge clamps attached in step 14.
18. Install the four paper height sensors [K] from the front side of the machine, as shown.
19. Install the four cable clamps [L], then clamp the cables.

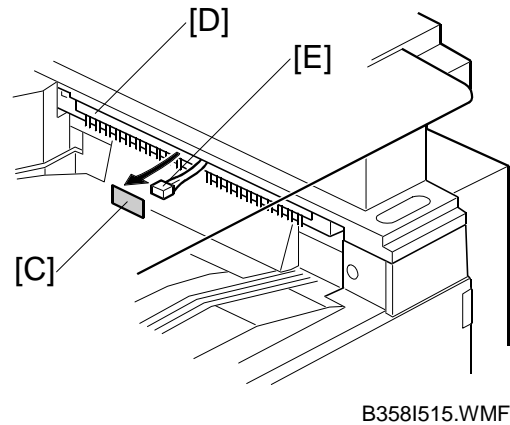
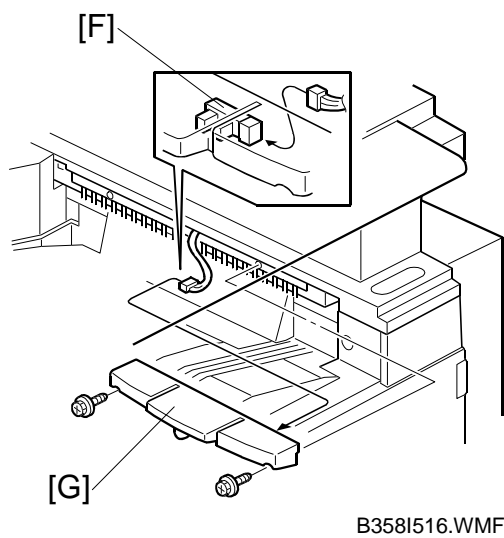
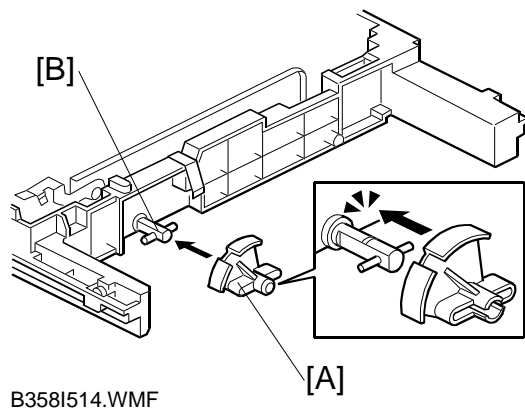

Installation

20. Install the paper height sensor actuator [A] on the bottom plate shaft [B] of each paper tray.
21. Reassemble the machine.

Paper Limit Sensor and Paper Sensor Installation

If the optional bridge unit has been installed, skip steps 22 and 23.

22. Peel off the black tape [C] from the anti-static brush [D], then pull out the cable [E].
23. Connect the cable to the sensor [F], then install the paper limit sensor unit [G] (2 screws).

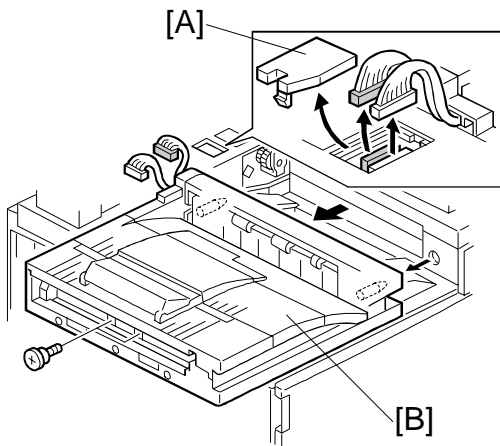

B3581518.WMF

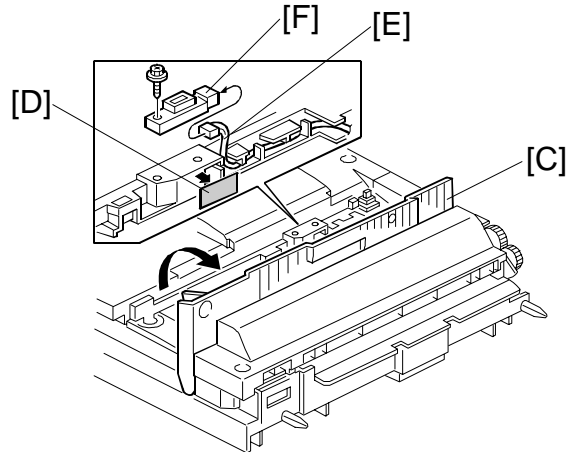

B3581517.WMF

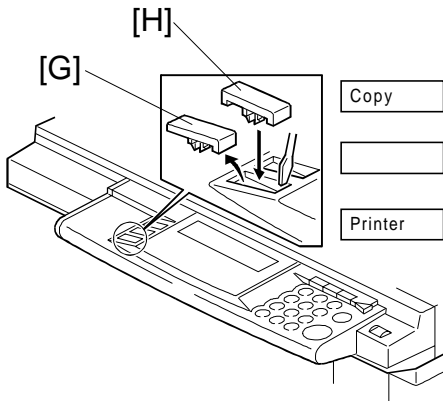

B3581501.WMF

Perform steps 24 to 26 only if the optional bridge unit has been installed. If it has not been installed, go on to step 27.

24. Remove the connector cover [A] and bridge unit [B] (2 screws, 2 connectors).
25. Open the right cover [C] of the bridge unit and peel off the black tape [D], then pull out the connector [E].
26. Install the paper sensor [F] (1 screw, 1 connector) and reinstall the bridge unit.
27. Remove the bottom cap [G] of the operation panel.
NOTE: If both the Scanner Option Type 450e and Fax Option Type 450e have not been installed, remove the top cap of the operation panel as well.
28. Install the **Printer** key [H] on the operation panel as shown.
NOTE: If both the Scanner Option Type 450e and Fax Option Type 450e have not been installed, install the **Copy** key on the operation panel as well (see the illustration).

29. Make sure that the parallel cable is not connected to the controller. Turn the machine on and check the setting of the following copier SP mode:
 - SP5-907: Plug & Play Brand Name and Production Name Setting – select the correct one.
30. If the customer wishes to expand the hard disk space in the mainframe for use by the printer, change the setting of “Memory Priority” (User Tool – 1. System – No.23) to “Printer”.
31. Print the Printer Configuration Page (User Tool – 4. Printer – 7. List Print – 5. Configuration Page) to check the printer controller connection.
32. If the parallel cable is going to be connected, first turn off the machine. After connecting the cable, turn the machine back on.

3.2 HARD DISK

3.2.1 INSTALLATION PROCEDURE

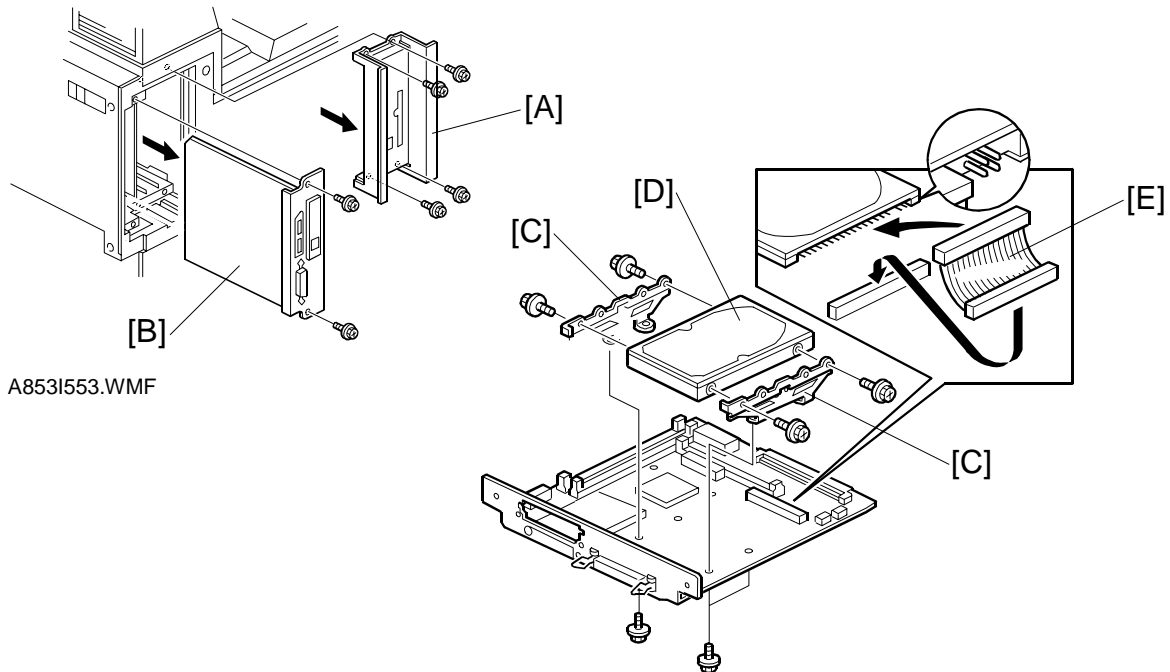

A8531553.WMF

A8531506.WMF

CAUTION

Unplug the copier power cord before starting the following procedure.

NOTE: If installing this hard disk drive and the printer controller (B358) at the same time, skip steps 1 and 2.

1. Remove the plate [A] (4 screws).
2. Remove the printer controller [B] (2 screws).
3. Attach the HDD brackets [C] to the hard disk drive [D] as shown (2 screws each).
4. Connect the cable [E] to the hard disk drive.
5. Attach the hard disk drive to the printer controller (4 screws, 1 connector).
6. Install the printer controller into the mainframe (refer to the Printer Controller Installation Procedure).
7. Reattach the plate [A].
8. After turning on the main switch and pressing the printer key, you will be prompted to format the disk drive.
Press the **①** key twice to format the disk.
9. After formatting the hard disk, turn the main switch off and on.

3.3 POSTSCRIPT KIT

3.3.1 INSTALLATION PROCEDURE

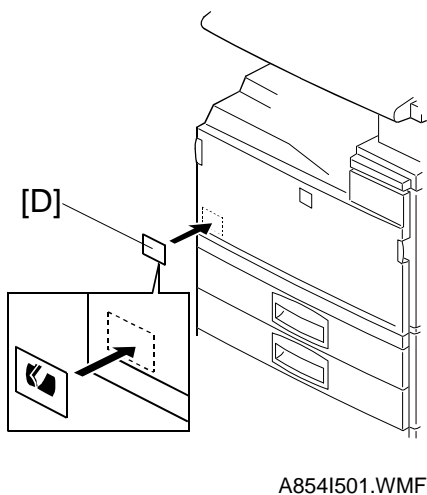
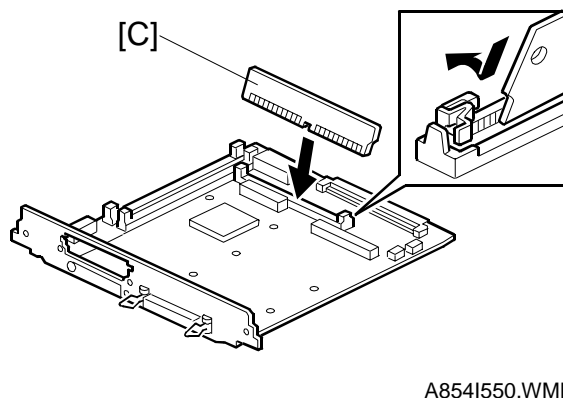
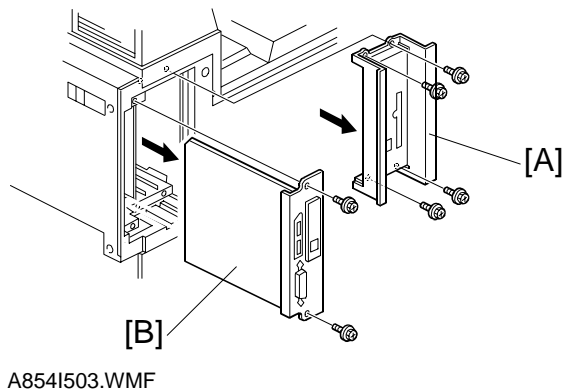

Installation

CAUTION

Unplug the copier power cord before starting the following procedure.

NOTE: If installing this PostScript Kit and the printer controller (B358) at the same time, skip steps 1 and 2.

1. Remove the plate [A] (4 screws).
2. Remove the printer controller [B] (2 screws).
3. Install the PostScript kit [C], as shown.
NOTE: Make sure that the PostScript kit is set properly.
4. Install the printer controller into the mainframe (refer to the Printer Controller Installation Procedure).
5. Reattach the plate [A].
6. Attach the PostScript decal [D] to the front cover, as shown.

3.4 NETWORK INTERFACE BOARD

3.4.1 INSTALLATION PROCEDURE

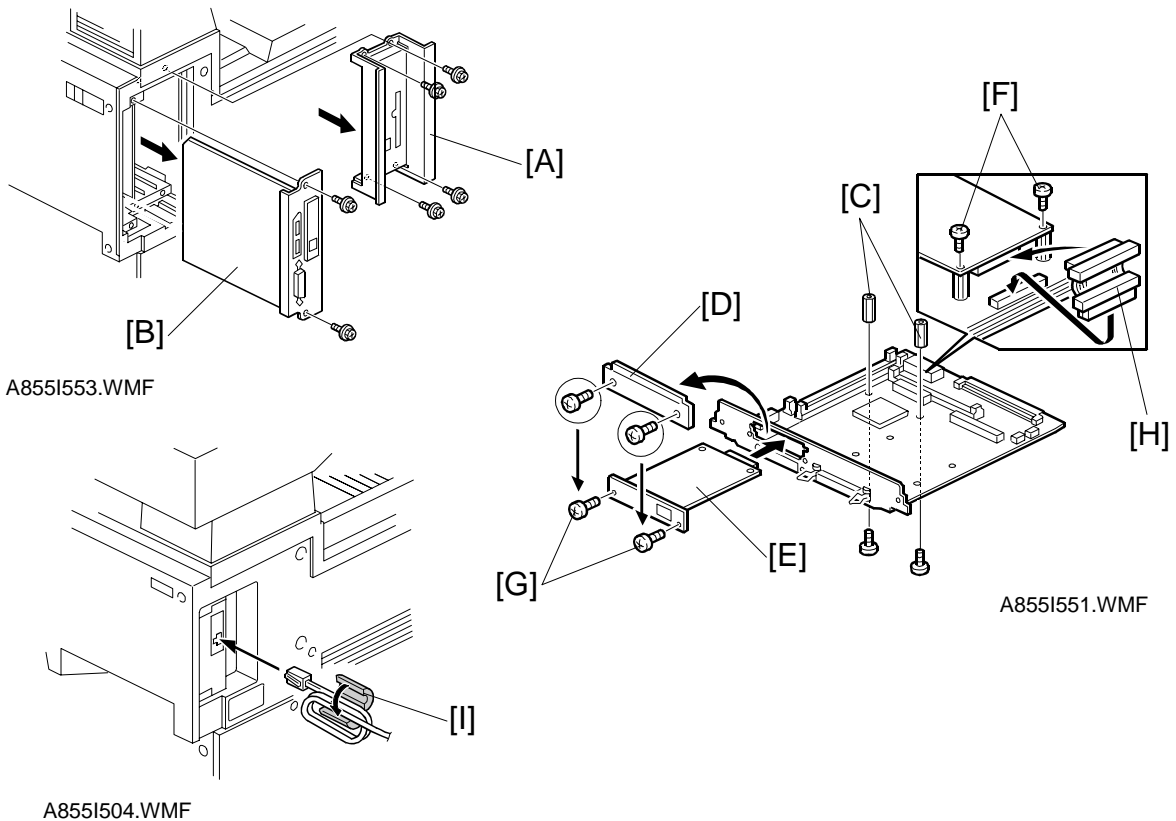

⚠ CAUTION

Unplug the copier power cord before starting the following procedure.

NOTE: If installing this network interface board and the printer controller (B358) at the same time, skip step 1.

1. Remove the plate [A] (4 screws) and the printer controller [B] (2 screws).
2. Attach two spacers [C] to the printer controller (1 screw each).
3. Remove the cover bracket [D] (2 screws).
4. Install the network interface board [E] using the 2 screws [F] in the accessory box and the 2 screws [G] that were used for the cover bracket [D].
5. Connect the cable [H] to both the network interface board and the printer controller.
6. Install the printer controller into the mainframe (refer to the Printer Controller Installation Procedure).
7. Reattach the plate [A].
8. Attach the core [I] to the network (STP) cable as shown.

NOTE: The STP cable should be coiled twice inside the core as shown.

3.5 DRAM SIMM

3.5.1 REQUIRED SPECIFICATION CHECK

Before installing the DRAM SIMM, check that it satisfies the requirements below.

Type	PC Compatible
Number of bins	72 pins
Access speed	70 ns or faster
Capacity	8, 16, or 32 MB
Parity	Any OK

3.5.2 INSTALLATION PROCEDURE

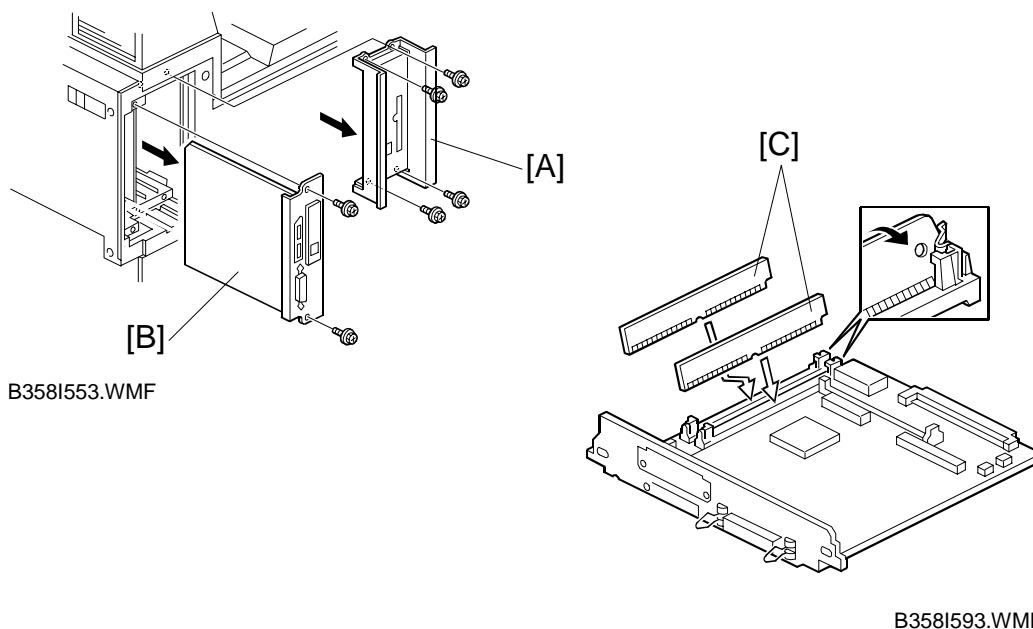

⚠ CAUTION

Unplug the copier power cord before starting the following procedure.

NOTE: Installing this DRAM SIMM and the printer controller (B358) at the same time, skip step 1.

1. Remove the plate [A] (4 screws) and the printer controller [B] (2 screws).
2. Install the DRAM SIMM [C], as shown.
NOTE: Make sure that the DRAM SIMM is installed properly.
3. Install the printer controller in the mainframe (refer to the Printer Controller Installation Procedure).
4. Reattach the plate [A].

3.6 CONNECTING THE INTERFACE CABLES

3.6.1 PARALLEL INTERFACE

An IEEE1284 compatible printer cable is required to connect the printer controller to a host PC parallel port.

3.6.2 NETWORK INTERFACE

An STP (Shielded Twisted Pair) cable with RJ45 connectors is required to connect the Network Interface Board to the computer network. (The cable should be Category/Type 5 or better.) After hardware setup, the network setup should be done by the user. The setup procedure is described in the NIB manual.

3.7 CHECKING THE CONNECTIONS

3.7.1 CONNECTION BETWEEN PRINTER CONTROLLER (and related options; PostScript ROM, DRAM SIMM, Hard Disk Drive, NIB) AND ENGINE.

1. Plug in the power cord and turn on the main and operation switches.
2. Enter the printer user mode.
 - 1) Press the User Tool key.
 - 2) Press 4 using the ten-key pad.
3. Print out the printer configuration page.
 - 1) Press the Next button then press 7 using the ten-key pad to select List Printing.
 - 2) Press the Next button then press 5 using the ten-key pad to print the configuration page. The machine prints the printer configuration page automatically.

NOTE: For more detailed information about the operation panel settings, refer to the operation manual.

The printer configuration page is similar to that shown on the next page.

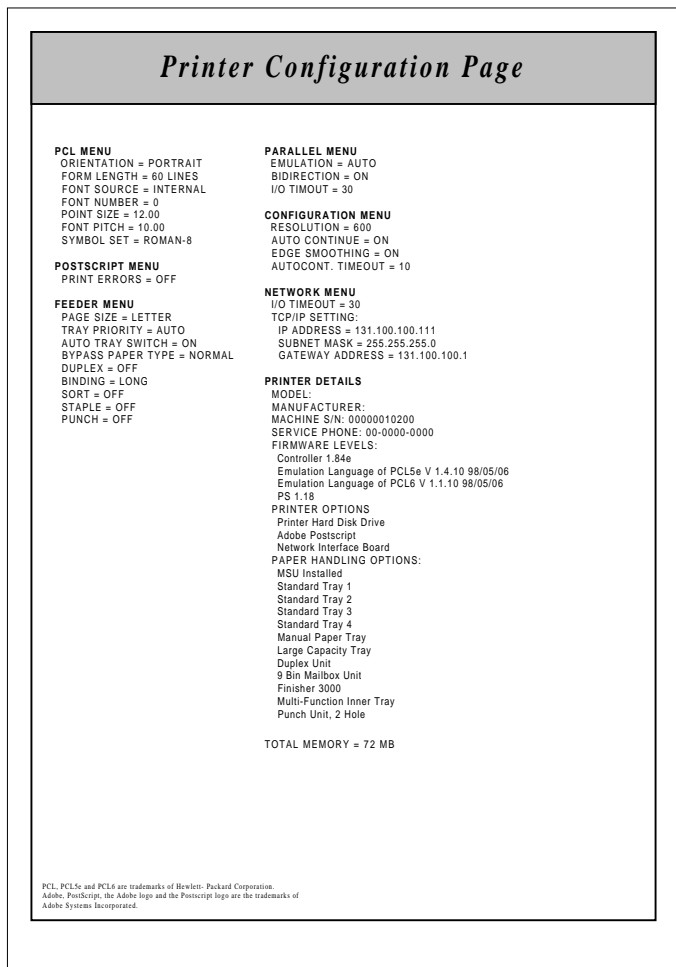

CONFIGURATION MENU

RESOLUTION = 600
 AUTO CONTINUE = OFF
 EDGE SMOOTHING = ON
 AUTOCONT.TIMEOUT = 10

[C]

NETWORK MENU

I/O TIMEOUT = 30
 TCP/IP SETTING:
 IP ADDRESS = 131.100.100.111
 SUBNET MASK = 255.255.255.0
 GATEWAY ADDRESS = 131.100.100.1

PRINTER DETAILS

MODEL:
 MANUFACTURER:
 MACHINE S/N: 00000010200
 SERVICE PHONE: 00-0000-0000

[D]

FIRMWARE LEVELS:

Controller 1.84e
 Emulation Language of PCL5e V 1.4.10 98/05/06
 Emulation Language of PCL6 V 1.1.10 98/05/06
 PS 1.18

PRINTER OPTIONS:

Printer Hard Disk Drive
 Adobe Postscript
 Network Interface Board

[A]

PAPER HANDLING OPTIONS:

MSU Installed
 Standard Tray 1
 Standard Tray 2
 Standard Tray 3
 Standard Tray 4
 Manual Paper Tray
 Large Capacity Tray
 Duplex Unit
 9 Bin Mailbox Unit
 Finisher 3000
 Multi-Function Inner Tray
 Punch Unit, 2 Hole

[B]

TOTAL MEMORY = 72 MB



B3581554.WMF

B3581505.WMF

Check the following:

- For the printer controller board, confirm that the machine prints the printer configuration page.
- For the hard disk drive and PS kit, confirm that the configuration page includes them in the “Printer Options” section [A].
- For DRAM SIMM, confirm that “Total Memory” [B] printed on the configuration page shows the correct amount of memory in the machine (including the 8 MB on board and the SIMM).
- For the NIB, confirm that the configuration page includes the “Network Menu” section [C] and includes the network interface board in the “Printer Options” section [A].
- For the firmware version, check “Firmware Levels” [D].

If any problem occurs with the above checks, reinstall the printer controller and other options. Then set up the machine again and redo the test.

3.7.2 CONNECTION BETWEEN MAIN CONTROLLER BOARD AND THE NETWORK INTERFACE BOARD

There are two ways to check the connection between the main controller board and the network interface board.

1. Check "Network Menu" on the configuration page.
2. Check the Network Interface Board Status Sheet with the network information that is printed automatically after power on.

Printing the Network Interface Board Status Sheet

Whenever the main switch is turned on, the machine prints the network interface board status sheet automatically.

NOTE: If the machine does not print the status sheet, check the Network menu in the printer user tools.

If any problem occurs with the above check, reinstall the printer controller and other options. Then set up the machine again and redo the test.

4. SERVICE TABLE

4.1 GENERAL CAUTION



Do not turn off the machine or switch the controller off-line when the data LED is blinking or is lit, or the data which has been sent to the controller will be lost. If you need to do this, ask the customer for consent.

4.2 SERVICE PROGRAM MODE

4.2.1 SERVICE PROGRAM ACCESS PROCEDURE

The service program access procedure, such as “Entering Service Program (SP) Mode” and “Exiting SP Mode” is the same procedure as for copier and fax, as follows.

Entering SP mode

 → ① → ① → ⑦ →  (hold it for more than 3 seconds.)

Exiting SP mode

Press the “Back” and “Exit” keys until the standby mode display appears.

4.2.2 SERVICE PROGRAM MODE TABLES

No.	Description	Function
01	Flash System From Parallel	Downloads the printer controller firmware from a PC through the parallel port.
02	Flash System From PCMCIA	Downloads the printer controller firmware using an IC card through the PCMCIA port.
03	Flash Postscript From Parallel	Downloads the PostScript firmware from a PC through the parallel port.
04	Flash Postscript From PCMCIA	Downloads the PostScript firmware using an IC card through the PCMCIA port.
05	Copy Flash ROM	Copies the printer controller firmware between ROM DIMM and printer controller
06	Format Disk	Formats the hard disk drive
07	Print Job Log Data	Prints the print/job count log page
08	Print Error Log Data	Prints the printer error log page
09	Clear Job Log Counter	Clears the print/job counter
10	Clear Error Log Data	Clears the error log counter
11	Parallel Loop Back Test	Performs the parallel loop back test

4.3 DOWNLOADING NEW FIRMWARE

New firmware for the printer controller and PostScript can be downloaded from a PC through the parallel cable and from a flash memory card through the PCMCIA port.

4.3.1 FIRMWARE UPDATE USING A FLASH MEMORY CARD (SP02 AND 04)

1. Prepare a flash memory card that has been programmed with the latest firmware.
NOTE: When you program a flash memory card with a firmware file, use the following parameter settings.
 - Start Address – 000000h
 - Length – 3FFFFFFh
2. Turn off the machine, remove the cover [A], and insert the flash memory card [B] into the slot so that the “A” side of the card faces the front of the machine.

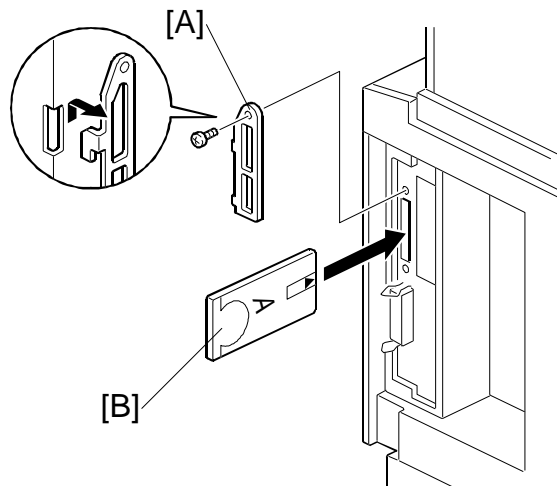

B358M501.WMF

3. Turn on the machine and enter the printer SP mode.
4. Choose “02 – Flash System From PCMCIA” or “04 – Flash Postscript From PCMCIA” depending on the firmware type.
5. Press “Yes” in reply to the confirmation message. Firmware download will take several minutes.
6. After new firmware has been downloaded successfully, turn off the machine, remove the card from the slot, and turn the machine back on.
7. Print the “Printer Configuration Page” to check the new firmware version ([User Tools] – [4. Printer] – [7. List Print] – [5. Configuration Page]). The firmware version number is printed in the “Printer Details” section of the configuration page.

4.3.2 FIRMWARE UPDATE FROM PARALLEL PORT (SP01 AND 03)

1. Prepare the latest firmware file and Fcopy.exe on a host computer.
2. Turn off the machine, connect the host computer using a parallel cable, and turn the machine back on.
3. Enter the printer SP mode.
4. Choose “01 – Flash System from Parallel” or “03 – Flash Postscript From Parallel” depending on the firmware type.
5. Press “Yes” in reply to the confirmation message.
6. On the host computer, start MS-DOS Prompt and type the following command.

Either

C:\> FCOPY path\filename

or

C:\> COPY /b path\filename port

CAUTION: Do not turn off the machine while “Downloading New System Software” is displayed on the LCD, even if FCOPY has finished in the MS-DOS Prompt.

7. After new firmware has been downloaded successfully, turn off the machine, disconnect the printer cable if necessary, and turn the machine back on.
8. Print the “Printer Configuration Page” to check the new firmware version ([User Tools] – [4. Printer] – [7. List Print] – [5. Configuration Page]). The firmware version number is printed in the “Printer Details” section of the configuration page.

4.3.3 FORMATTING THE HARD DISK (SP06)

This function is used to format the printer hard disk. If the hard disk is formatted, the stored data (downloaded fonts and macros) will be erased. So, when performing this function, ask the customer for consent. After this operation, advise the customer to restore their data, if necessary.

1. Enter the printer SP mode.
2. Choose “06 – Format Disk”.
3. Press “Yes” in reply to the confirmation message. Hard disk formatting will take several minutes.
4. After confirming that formatting was successful, turn the machine off and back on again.

4.3.4 COPY FLASH ROM (SP05)

There are two functions; one is to copy the printer controller firmware from the ROM DIMM to the printer controller, the other is the opposite way.

Download from ROM SIMM to printer controller

When downloading the printer controller firmware from either the flash memory card or a PC was not successful and the printer controller does not start up, the controller firmware cannot be downloaded from the flash memory card or a PC to recover the machine. However, the firmware can be downloaded from ROM SIMM using this function, using the following procedure.

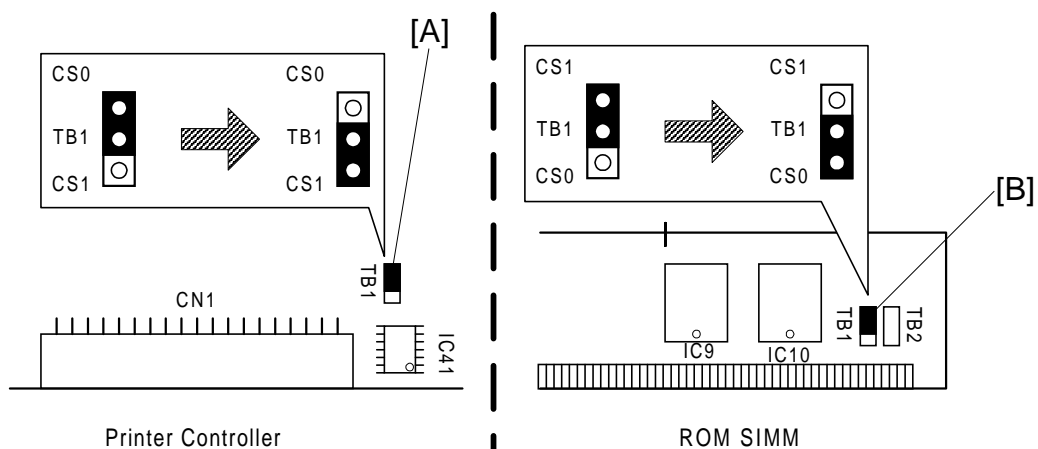

B358M500.WMF

1. Remove the printer controller.
 2. Change the position of the TB1 jumper [A] on the controller from CS0 to CS1.
 3. Change the position of the TB1 jumper [B] on the ROM DIMM that contains the controller firmware from CS1 to CS0.
 4. Install the ROM SIMM on the controller.
- CAUTION:** Make sure to install the correct ROM SIMM in the PostScript SIMM.
5. Install the printer controller and turn on the machine.
 6. Enter the printer SP mode and select "05 – Copy Flash ROM".
 7. Press "Yes" in reply to the confirmation message.
 8. After downloading is successful, turn off the machine and remove the printer controller then remove the ROM SIMM as well.
 9. Reposition the jumpers on the printer controller and ROM SIMM.
 10. Reinstall the printer controller then turn on the machine.
 11. Check that the printer controller starts up.

Download from the controller to ROM SIMM

CAUTION: Never perform this function if the PostScript ROM SIMM is installed on the controller. Otherwise, the controller firmware will be copied to the PostScript kit. Take out the PostScript ROM SIMM and install a blank one.

1. Remove the printer controller.
2. Install the ROM SIMM on the controller.
3. Install the printer controller and turn on the machine.
4. Enter the printer SP mode and select "05 – Copy Flash ROM".
5. Press "Yes" in reply to the confirmation message.
6. After downloading is successful, turn off the machine and remove the printer controller then remove the ROM SIMM as well.
7. Reinstall the printer controller then turn on the machine.

4.3.5 PARALLEL LOOP BACK TEST (SP11)

1. Plug the loop back connector into the parallel port of the printer.
2. Enter the printer SP mode then select "11 – Parallel Loop Back Test".
3. Press "Yes" in reply to the confirmation message. The result of the test will be displayed on the operation panel.

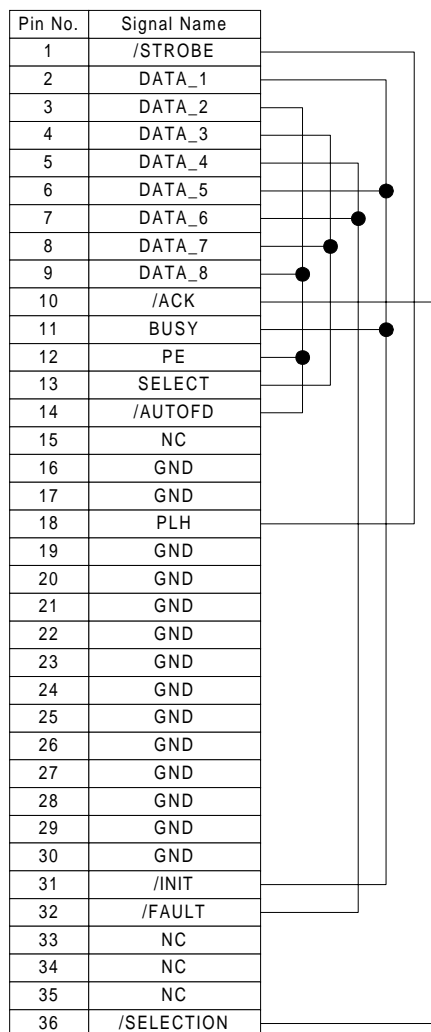

Service Tables

4.4 USER PROGRAM MODE

A user program (UP) mode is available for printer features as well as for copy and fax. Press the User Tools button to access it.

4.4.1 UP MODE TABLE

NOTE: The function of each UP mode is explained in the Printer Reference section of the operating instructions.

1. PCL	1. Orientation	
	2. Form Lines	
	3. Font Source	
	4. Font Number	
	5. Point Size	
	6. Font Pitch	
	7. Symbol Set	
2. Postscript	1. Print Errors	
3. Paper Feed	1. Input	1. Paper Size
		2. Tray Priority
		3. Auto Tray Switch
		4. Bypass Paper Type
	2. Output	1. Duplex
		2. Sort
		3. Staple
		4. Punch
4. Parallel	1. Emulation	
	2. Bi-direction	
	3. I/O Timeout	
5. Network	1. I/O Timeout	
	2. TCP/IP Menu	
6. Configuration	1. Resolution	
	2. Auto Continue	
	3. Edge Smoothing	
	4. Autocont. Timeout	
7. List Print	1. PS Font List	
	2. PCL Font List	
	3. PS Demo Page	
	4. PCL Demo Page	
	5. Configuration Page	
8. Reset Select	1. Job Reset	
	2. Menu Reset	
	3. System Reset	

4.5 DIP SWITCHES/JUMPER PINS/LEDS

4.5.1 DIP SWITCHES

SW2:

No.	Function	On	OFF
1	Destination for firmware downloading	To flash ROM	To ROM SIMM
2	<i>Not used</i>	<i>Do not change this setting. Keep these both off.</i>	
3			
4	Operation mode	Normal operation	Programming firmware

NOTE: The functions of DIP switches no.1 is enabled when changing the setting of no.4 to the off position. However, **do not change the default settings.** Always do the firmware downloading using SP mode.

4.5.2 JUMPER PINS

TB1:

Function	CS0	CS1
Bank setting for resident flash ROM	Bank setting for flash ROM is "0".	Bank setting for flash ROM is "1".

TB2:

Function	UN-PROT	PROT
Not used	Do not change this setting. Keep at "UN-PROT".	

4.5.3 LEDS

Symbol	Function
PWR	This LED turns on when +5 V is supplied to the printer controller.
LED2	Refer to section 6.2 (LEDS) for more detail.
LED3	
LED4	
LED5	

4.6 SPECIAL TOOLS

Part Number	Description	Q'ty
A8545120	ROM SIMM	1
G0219350	Loop Back Connector	1

5. REPLACEMENT AND ADJUSTMENT

⚠ CAUTION

Turn off the main power switch and unplug the machine before attempting any of the procedures in this section.

5.1 PRINTER CONTROLLER BOARD

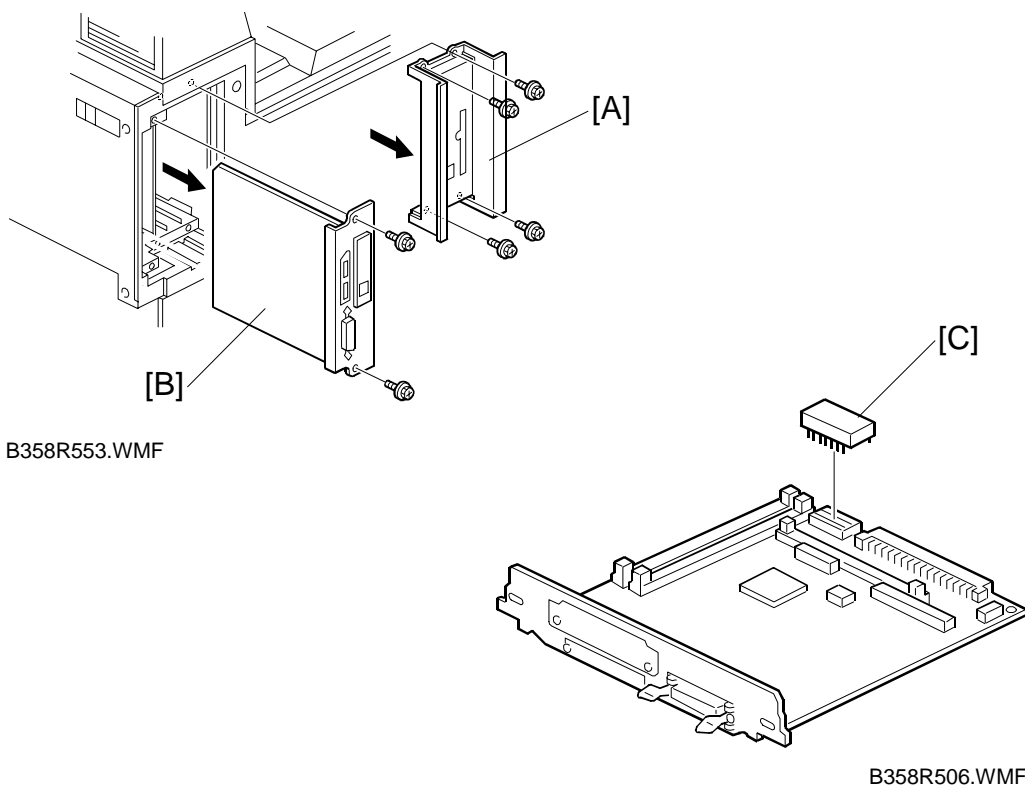

Replacement
Adjustment

1. Remove the printer cables from the printer controller.
2. Remove the plate [A] (4 screws).
3. Slide out the printer controller board [B] (2 screws).
4. Remove the optional hard disk, network interface board, PS kit, and DRAM SIMMs if they are installed (see their replacement procedures).
5. Remove the NVRAM [C] from the old printer controller and install it on the new printer controller.
6. Install the options on the new printer controller.
7. Reattach the plate [A].

5.2 HARD DISK

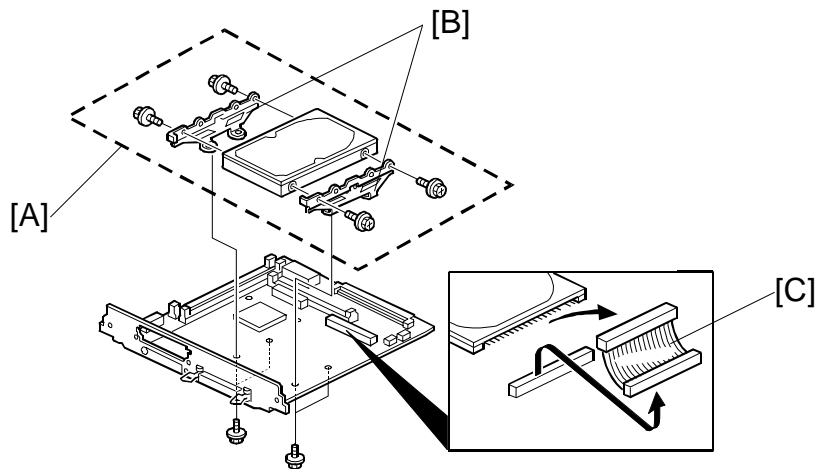

B358R504.WMF

1. Slide out the printer controller (see Printer Controller).
2. Dismount the hard disk [A] with bracket and IDE cable from the printer controller (4 screws).
3. Remove two brackets [B] (2 screws each).
4. Disconnect the IDE cable [C].

5.3 NETWORK INTERFACE BOARD

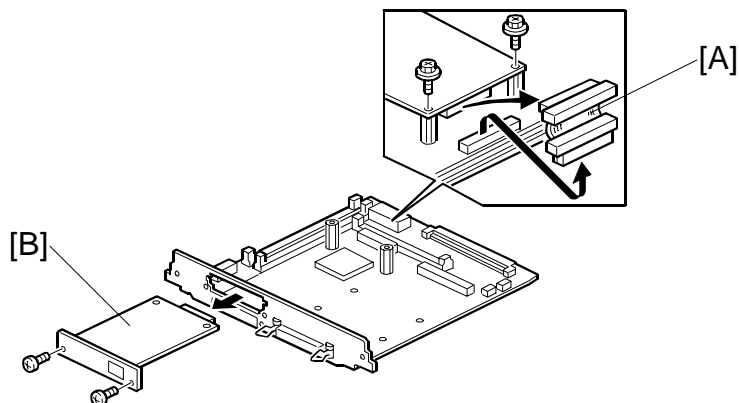

B358R503.WMF

1. Slide out the printer controller (see Printer Controller).
2. Disconnect the cable [A] from the printer controller and network interface board.
3. Remove the network interface board [B] (4 screws).

5.3.1 POSTSCRIPT ROM BOARD AND DRAM SIMM

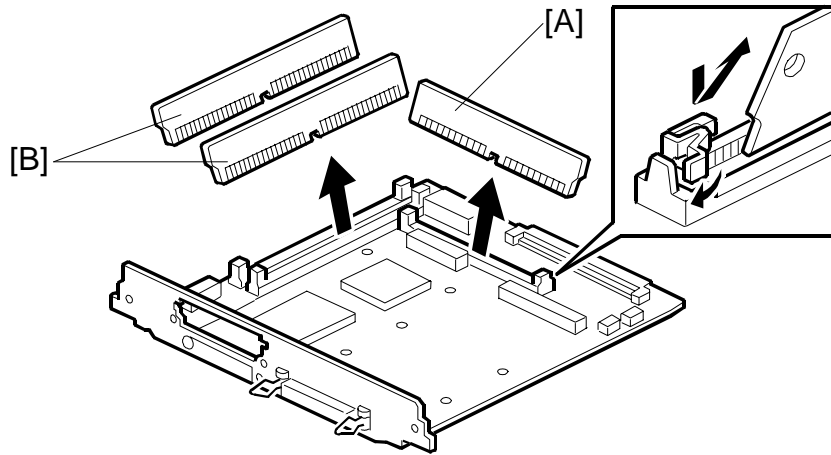

B358R505.WMF

1. Slide out the printer controller (see Printer Controller).
2. Remove the PS ROM board [A].
3. Remove the DRAM SIMMs [B].

Replacement
Adjustment

6. TROUBLESHOOTING

6.1 ERROR MESSAGES

If an error occurred, the error LED lights (red light with the printer key) and an error message is displayed on the LCD.

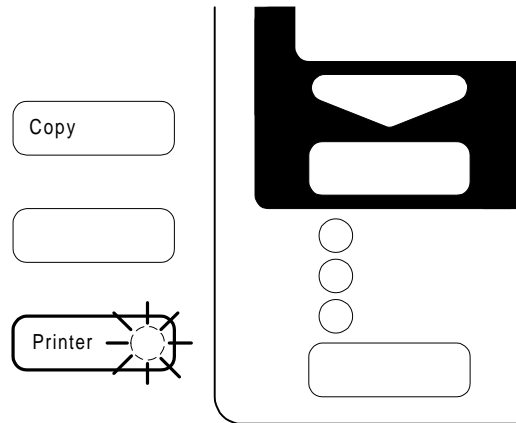

B358T501.WMF

Service Call (SC) Codes

SC No.	Description / Definition	Possible Cause
SC2000	Functional problems (Self diagnostic error)	Printer controller board defective.
	A diagnostic error occurred at power on. The controller has a hardware problem.	
SC2001	Functional problems (Debug trap error)	The controller software has a problem.
	An error has occurred in the controller. The controller has a software problem.	
SC2002	Functional problems (Exception error)	Printer controller board defective.
	An error has occurred in the controller. The controller has a software or hardware problem.	

Trouble-shooting

Other Messages

The following errors might need assistance from service.

Error Message	Condition	Possible Cause
Printer HDD Error. Press Reset to cancel current job.	A hard disk error was detected during downloading the macro or fonts.	<ul style="list-style-type: none"> • Printer HDD defective • Printer controller defective
Parallel Communication Error. Please set up communication parameters in parallel menu. Press Reset to cancel current job.	Parallel communication error occurred during a print job via the parallel port.	<ul style="list-style-type: none"> • An item in the parallel menu was set incorrectly • Parallel cable defective • Printer controller defective
Print overrun. Press Reset to cancel current job, or press Continue to print.	This error occurred when a file was being printed in banding mode. A complex page may not have enough time to image a band while the engine is printing the previous page.	<ul style="list-style-type: none"> • Insufficient memory • A complex page is printed • The DRAM SIMM board is defective • The controller is defective
Memory overflow. Press Reset to cancel current job.	This error occurred during printing. The language has sent a file that is too complex to interpret in the available memory.	<ul style="list-style-type: none"> • Insufficient memory • A complex page is printed • The DRAM SIMM is board defective • The controller is defective

6.2 LE DS

6.2.1 LOCATION

Four LEDs (LED2 to LED5) are located near SW2 on the printer controller. They indicate display the progress of the self test, and errors and status conditions.

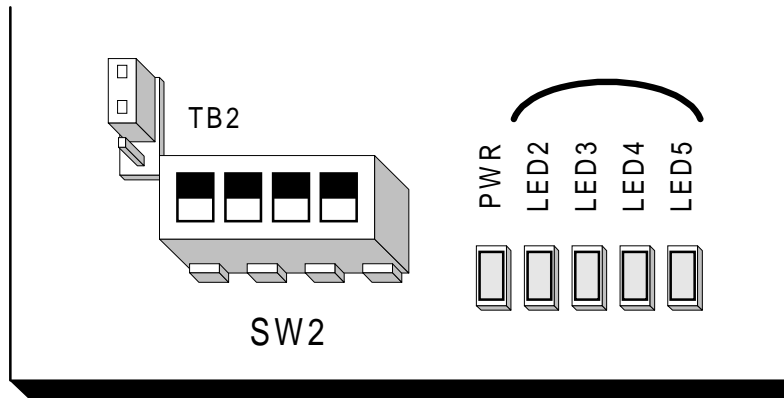

B358T500.WMF

6.2.2 LED CODE TABLE

Self Diagnostic

The following LED table is for the self diagnostic function. When an error occurs during the self diagnostic test, all four LEDs blink then indicate the error as shown in the following table.

e.g.) RAM error:

All LEDs on (1 s) → off (1 s) → on (1 s) → off (1 s) → LED4 on (5 s) → from the beginning.

1 = LED is lit, 0 = LED is off

LEDS				Description
LED2	LED3	LED4	LED5	
0	0	0	1	ROM error
0	0	1	0	RAM (resident, SIMM) error: <small>note 1)</small>
0	0	1	1	NVRAM error: <small>note 1)</small>
0	1	0	1	Fatal error
0	1	1	0	Debug trap error: <small>note 2)</small>

NOTE: 1) SC2000 is also displayed.

2) SC2002 is also displayed.

Trouble-shooting

Controller Firmware Copy/Download

During controller firmware copying and downloading, the following LED status will be indicated.

1 = LED is lit, 0 = LED is off, 1/0 = LED is blinking

LEDS				Description
LED2	LED3	LED4	LED5	
1	0	0	0	Data downloading
0	1/0	0	0	Erasing
1/0	1/0	1	0	Programming
0	0	0	1	Verifying
1	0	0	1	Insufficient RAM error
1	0	1	0	Verify failure
1	0	1	1	Download failure (check sum error)
1	1	0	0	Erase failure
1	1	0	1	Download failure (other error)
1	1	1	1	Copy/download success